





*United States of America  
Department of Transportation  
Federal Aviation Administration*

*Supplemental Type Certificate  
(Continuation Sheet)*

*Number: SE00226NY*

Date of Issuance: October 5, 1994, 1993

Date Amended: October 27, 1999

Date of Reissuance: March 9, 2016

Limitations and Conditions (Continued):

1. This approval is limited to aircraft with a 24-volt DC Source available to the starter.
2. Configuration I and III are limited to Sky-Tec Starter Model 149-24HT and Model 149-24HTL used with 149-tooth engine ring gear and starter drive ratio of 13.55:1 and Configuration II is limited to Sky-Tec Starter Model 122-24HT used with a 122-tooth engine ring gear and starter drive ratio of 13.55:1.
3. Configuration I and II are limited to Sky-Tec Starter Model 149-24HT and Model 122-24HT used with right-hand rotation Lycoming engines. Configuration III is limited to Sky-Tec Starter Model 149-24HTL used with left-hand rotation (L) Lycoming engines.
4. The installer must determine whether this design change is compatible with previously approved modifications. If the holder agrees to permit another person to use this certificate to alter a product, the holder must give the other person written evidence of that permission.

-END-

---

Any alteration of this certificate is punishable by a fine of not exceeding \$1,000, or imprisonment not exceeding 3 years, or both. This certificate may be transferred or made available to third persons by licensing agreements in accordance with 14 CFR 21.47. Possession of this Supplemental Type Certificate (STC) document by persons other than the STC holder does not constitute rights to the design data nor to alter an aircraft, aircraft engine, or propeller. The STC's supporting documentation (drawings, instructions, specifications, flight manual supplements, etc.) is the property of the STC holder. An STC holder who allows a person to use the STC to alter an aircraft, aircraft engine, or propeller must provide that person with written permission acceptable to the FAA. (Ref. 14 CFR 21.120)

**FAA APPROVED MODEL LIST (AML)**

STC Number: **SE00226NY**

Date of issuance: October 5, 1994

Date amended: October 27, 1999, Revision 4

Hartzell Engine Technologies LLC  
2900 Selma Hwy  
Montgomery, AL 36108

Date of reissuance: March 9, 2016

Item	Engine Make	Engine Model	Original Type Certificate Number	Regulation/Part
1	Textron Lycoming	O-360 Series	E-286	CAR 13
2	AVCO Lycoming	TO-360 Series	E26EA	FAR 33
3	Textron Lycoming	IO-360 Series	IE10	CAR 13
4	AVCO Lycoming	IO-320 Series	IE12	CAR 13
5	Textron Lycoming	O-320 Series	E-274	CAR 13
6	Textron Lycoming	O-235 Series	E-223	CAR 13
7	AVCO Lycoming	O-290 Series	E-229	CAR 13
8	Textron Lycoming	O-540 Series	E-295	CAR 13
9	Textron Lycoming	IO-540 Series	IE4	CAR 13
10	Textron Lycoming	TIO-540 Series	E14EA	CAR 13
11	AVCO Lycoming	TIO-541 Series	E10EA	CAR 13
12	Textron Lycoming	IO-720 Series	IE15	CAR 13

FAA Approved:

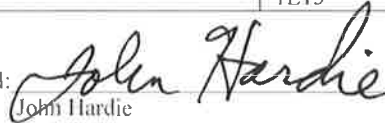

John Hardie

Acting Manager, Fort Worth Aircraft Certification Office,  
Southwest Region

Date: March 9, 2016

USER IS RESPONSIBLE FOR VERIFICATION OF CURRENT REVISION BEFORE USING THIS DOCUMENT. DOCUMENT CONSIDERED "REFERENCE ONLY" IF NOT THE CURRENT REVISION.

REVISIONS				
ECO	REV.	DESCRIPTION	BY	DATE
123685	T	1) FORMAT: HET WAS SKYTEC; 2) DESCRIPTION: ADDED "HT"; 3) REMOVED PMA LABEL & LABEL CHART; 4) NOTE 6: REMOVED SKYTEC PHONE NUMBER	EAB	11/09/16

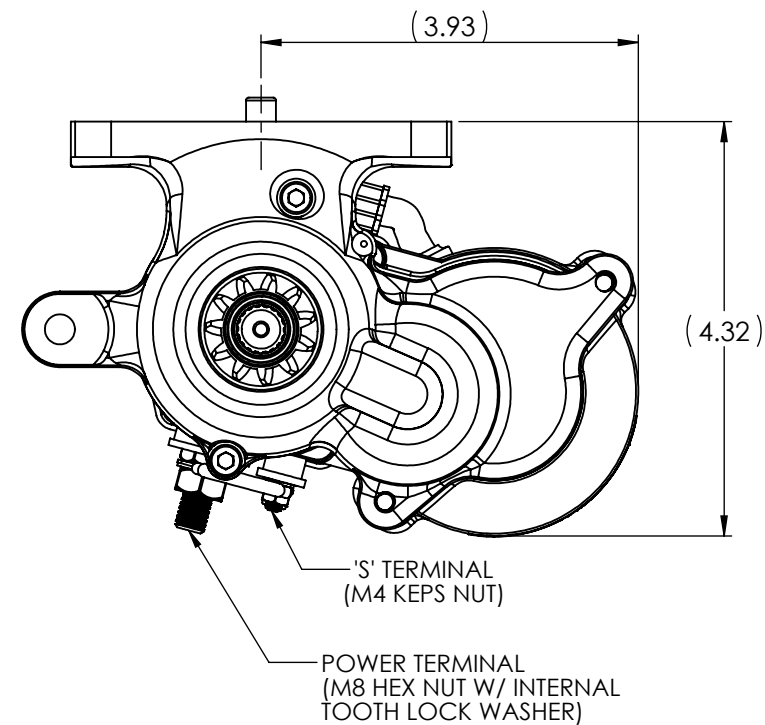
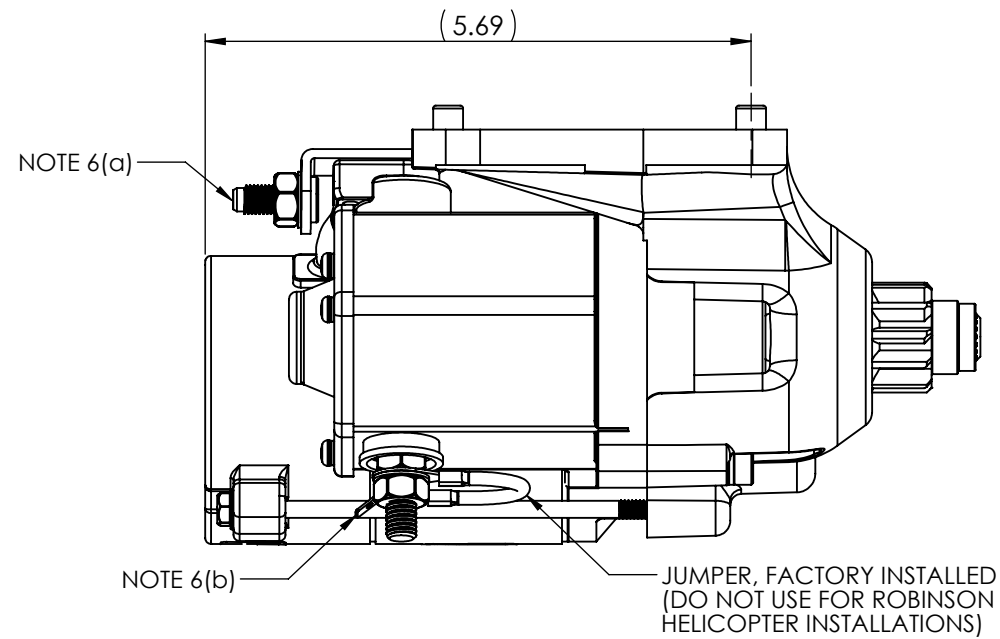

INSTALLATION INSTRUCTIONS:

- USE 3EA. AN315-5 5/16 NUTS AND 1EA. AN5 BOLT OF SUFFICIENT LENGTH FOR A MINIMUM OF 1/2" THREADS INTO ENGINE CASE.
- USE AN936-516 LOCK WASHERS UNDER EACH NUT AND UNDER HEAD OF BOLT.
- TORQUE MOUNTING BOLTS AND NUTS TO 100 INCH-POUNDS.
- TORQUE POWER TERMINAL NUT TO 60 INCH-POUNDS.
- CONTINUING AIRWORTHINESS: THE STARTER SHOULD BE OVERHAULED AT 2700 HOURS OR WHEN MAJOR OVERHAUL IS PERFORMED ON THE ENGINE ON WHICH IT IS INSTALLED. NO OTHER MAINTENANCE IS REQUIRED OR RECOMMENDED.
- OPTIONAL INSTALLATION AID PARTS:  
 (a) RUN-ON LIGHT CONNECTING POST, P/N 2405, AND,  
 (b) 1/4" QUICK-CONNECT TERMINAL P/N 2404 ARE AVAILABLE FOR ROBINSON HELICOPTER INSTALLATIONS

UNLESS OTHERWISE SPECIFIED DIMENSIONS ARE IN INCHES AND APPLY AFTER HEAT TREAT AND PLATING .X = ±.015 .XX = ±.010      ANGLES ±1° .XXX = ±.005 BREAK ALL EDGES AND MACHINE ALL INSIDE CORNER FILLETS .015 MAX. SURFACE FINISH	GEOMETRIC SYMBOLS PER ANSI Y14.5 — FLATNESS — STRAIGHTNESS — ROUNDNESS — CYLINDRICITY — PROFILE — PERPENDICULARITY — POSITION — CONCENTRICITY — SYMMETRY — ANGULARITY — PARALLELISM — CIRCULAR RUNOUT — TOTAL RUNOUT	DRAWN	EAB	11/09/16	 2900 Selma Highway Montgomery, AL 36108
		ENGINEER	K. NORD		
THIS DRAWING CONTAINS INFORMATION THAT IS CONFIDENTIAL AND PROPRIETARY TO HARTZELL ENGINE TECHNOLOGIES. THIS DRAWING IS FURNISHED ON THE UNDERSTANDING THAT THE DRAWING AND THE INFORMATION IT CONTAINS WILL NOT BE COPIED OR DISCLOSED TO OTHERS EXCEPT WITH THE WRITTEN CONSENT OF HARTZELL ENGINE TECHNOLOGIES. WILL NOT BE USED TO THE DETRIMENT OF HARTZELL ENGINE TECHNOLOGIES, AND WILL BE RETURNED UPON REQUEST BY HARTZELL ENGINE TECHNOLOGIES.	SCALE 1:2	APPRVD.	123685		HT INSTALLATION INSTRUCTIONS DRAWING NO. 10122
		FINISH	N/A		
		WEIGHT	N/A		REV. T
		MATERIAL	N/A		
		SIZE B	SH 1 OF 1	CODE ID 65PY1	DRAWING NO. 10122

SPECIFICATION CLASSIFICATION		
CLASSIFICATION	DIMENSION CONVENTION	NOTE NO. CONVENTION
CRITICAL	<XX.XX>	<#>
MAJOR	[XX.XX]	[#]
MINOR	XX.XX	#
REFERENCE	(XX.XX)	(#)