

REVISIONS				
ECO	REV.	DESCRIPTION	BY	DATE
123576	NEW	INITIAL RELEASE	LWE	10/26/16
124047	A	1) ITEM 2 QTY: A/R WAS 2; 2) ITEM 3: 50706 WAS 3510; 3) REMOVED ITEM 4; 4) ADDED NOTE 1 FLAG; 5) ADDED NOTE 9; 6) MOVED ITEM 2 BALLOON	EAB	02/02/17

NOTES:

- 1. OVERALL LENGTH OF WIRE, STARTER TO SWITCH, 6'.
- 2. REMOVE PULL START CABLE AND ENLARGE PANEL HOLE, IF REQUIRED, TO 5/8".
- 3. ATTACH 5/16" RING LUG TO POWER BOLT OF STARTER ALONG WITH STARTER POWER CABLE. TIGHTEN NUT ON POWER BOLT TO 50 INCH/POUNDS.
- 4. ATTACH #8 RING LUG ON SAME END OF CABLE AS LUG IN #3, ABOVE, TO SMALL S-TERMINAL ON STARTER. TIGHTEN NUT ON THIS TERMINAL.
- 5. ROUTE FREE ENDS OF WIRES THROUGH FIREWALL USING HOLE THAT PULL-CABLE WENT THROUGH. SEAL FIREWALL HOLE WITH HIGH-TEMP SILICONE OR SIMILAR MATERIAL.
- 6. SECURE THE RING LUGS UNDER EACH OF THE SWITCH SCREWS.
- 7. REMOVE FACE NUT FROM SWITCH AND ADJUST BACKING NUT FOR PANEL THICKNESS. INSERT SWITCH THROUGH PANEL FROM BEHIND AND SECURE WITH FACE NUT AS SHOWN.
- 8. TIE EXCESS WIRE SECURELY BEHIND PANEL.
- 9. ALL COMPONENTS LISTED ARE PACKAGED SEPARATELY IN PURCHASED KIT. ASSEMBLY IS TO BE PERFORMED BY PURCHASER DURING INSTALLATION USING DIAGRAM BELOW.

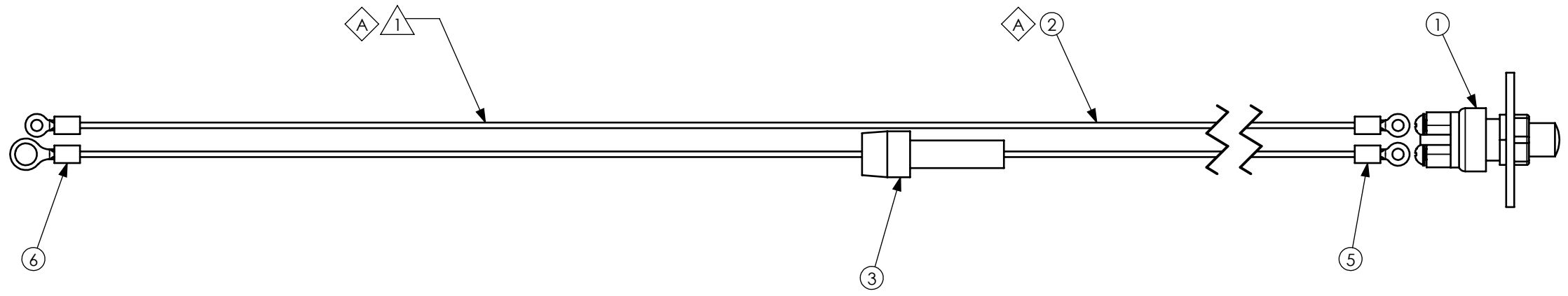

ITEM NO.	PART NUMBER	DESCRIPTION	QTY.
1	3600	SWITCH, POLLACK 24-359	1
2	3101	#14AWG HIGH TEMP INSULATED WIRE	A/R
3	50706	FUSE & WIRE ASSEMBLY	1
4	-	-	-
5	3304-1	#8 RING TERMINAL	3
6	3303-1	5/16" RING TERMINAL	1

USER IS RESPONSIBLE FOR VERIFICATION OF CURRENT REVISION BEFORE USING THIS DOCUMENT. DOCUMENT CONSIDERED "REFERENCE ONLY" IF NOT THE CURRENT REVISION.

SPECIFICATION CLASSIFICATION		
CLASSIFICATION	DIMENSION CONVENTION	NOTE NO. CONVENTION
CRITICAL	<XX.XX>	<#>
MAJOR	[XX.XX]	[#]
MINOR	XX.XX	#
REFERENCE	(XX.XX)	(#)

UNLESS OTHERWISE SPECIFIED
 DIMENSIONS ARE IN INCHES AND APPLY AFTER HEAT TREAT AND PLATING
 .X = ±.015
 .XX = ±.010 ANGLES ±1°
 .XXX = ±.005
 BREAK ALL EDGES AND MACHINE ALL INSIDE CORNER FILLETS .015 MAX.
 SURFACE FINISH 125/√

THIS DRAWING CONTAINS INFORMATION THAT IS CONFIDENTIAL AND PROPRIETARY TO HARTZELL ENGINE TECHNOLOGIES. THIS DRAWING IS FURNISHED ON THE UNDERSTANDING THAT THE DRAWING AND THE INFORMATION IT CONTAINS WILL NOT BE COPIED OR DISCLOSED TO OTHERS EXCEPT WITH THE WRITTEN CONSENT OF HARTZELL ENGINE TECHNOLOGIES. WILL NOT BE USED TO THE DETRIMENT OF HARTZELL ENGINE TECHNOLOGIES, AND WILL BE RETURNED UPON REQUEST BY HARTZELL ENGINE TECHNOLOGIES.

GEOMETRIC SYMBOLS PER ANSI Y14.5	
[Symbol]	FLATNESS
[Symbol]	STRAIGHTNESS
[Symbol]	ROUNDNESS
[Symbol]	CYLINDRICITY
[Symbol]	PROFILE
[Symbol]	PERPENDICULARITY
[Symbol]	POSITION
[Symbol]	CONCENTRICITY
[Symbol]	SYMMETRY
[Symbol]	ANGULARITY
[Symbol]	PARALLELISM
[Symbol]	CIRCULAR RUNOUT
[Symbol]	TOTAL RUNOUT
SCALE 1:2	

DRAWN	LWE	10/26/16
ENGINEER	K. NORD	
APPRVD.	124047	
FINISH	N/A	
WEIGHT	N/A	
MATERIAL SEE INDIVIDUAL COMPONENTS		
SIZE B	SH 1 OF 1	CODE ID 65PY1

HARTZELL ENGINE TECHNOLOGIES
 2900 Selma Highway
 Montgomery, AL 36108

PUSH BUTTON
STARTER SWITCH ASSEMBLY

DRAWING NO. 71001	REV. A
----------------------	-----------