

INSTALLATION INSTRUCTIONS:

1. DISCONNECT POWER CABLE AND UNBOLT OLD STARTER FROM ENGINE.
2. INSTALL NEW STARTER USING EXISTING NUTS AND WASHERS.
3. TIGHTEN NUTS TO TORQUE SHOWN IN CONTINENTAL "ENGINE OVERHAUL MANUAL".
4. ATTACH POWER CABLE TO THE POWER TERMINAL ON THE STARTER USING HARDWARE SUPPLIED. TIGHTEN TO 50 IN-LBS.
5. INSTRUCTIONS FOR CONTINUED AIRWORTHINESS: THE STARTER MAY BE REPLACED AT 2700 HOURS OR WHEN A MAJOR OVERHAUL IS PERFORMED ON THE ENGINE ON WHICH IT IS INSTALLED. NO OTHER MAINTENANCE IS REQUIRED OR RECOMMENDED.
6. IF DURING INSTALLATION IT IS NOTED THAT THE SOLENOID WILL INTERFERE WITH OTHER COMPONENTS, THE SOLENOID CAN BE REORIENTED BY REMOVING THE THREE (3) 1/4-20 CAP SCREWS AND ROTATING THE STARTER BODY IN THE FLANGE TO A SET OF HOLES THAT WILL PROVIDE CLEARANCE. NOTE THAT THE PATTERN OF HOLES WILL ALLOW 40° INCREMENTS AND IF THE MOUNTING FLANGE IS ROTATED 180°, THE 40° CAN BE OFFSET BY 20°. THIS WILL ALLOW THE SOLENOID TO BE LOCATED IN ANY OF 18 POSITIONS. APPLY LOCTITE 222MS TO THE THREADS OF THE THREE (3) 1/4-20 CAP SCREWS AND TIGHTEN TO 55-60 IN-LBS.
7. IN CASES WHERE THE STARTER CONTACTOR IS MOUNTED TO THE ORIGINAL STARTER, THE ST5'S SOLENOID CAN BE USED IN ITS PLACE BY REMOVING THE JUMPER AND CONNECTING THE WIRE FROM THE START SWITCH TO THE 'S' TERMINAL.

REVISIONS				
ECO	REV	DESCRIPTION	BY	DATE
129747	E	1) UPDATED TO NEW HET TITLEBLOCK; 2) REVISED NOTES 3 AND 5; 3) ADDED "APPLY LOCTITE TO..." TO THE END OF NOTE 6	OKQ	02/28/20

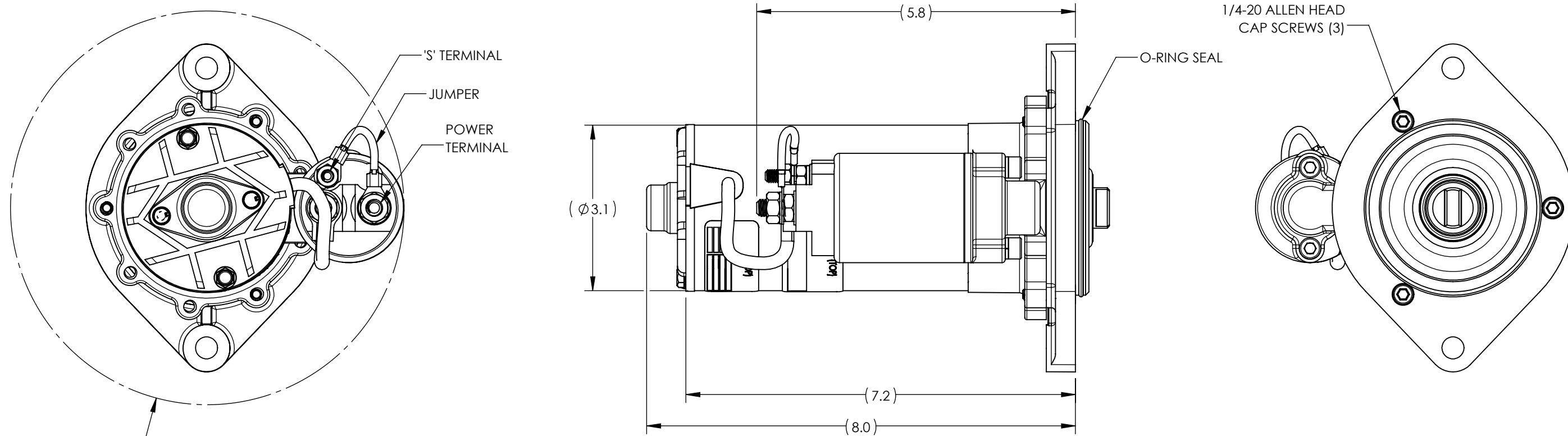

Ø7.3
THE SOLENOID MAY BE INDEXED TO ANY OF 9 POSITIONS WITHIN THIS CIRCLE FOR CLEARANCE AND POWER LEAD ATTACHMENT

UNLESS OTHERWISE SPECIFIED		
DIMENSIONS ARE IN INCHES AND APPLY AFTER HEAT TREAT AND PLATING .X±.015 .XX±.010 .XXX±.005 ANGLES±1° BREAK ALL EDGES AND MACHINE ALL INSIDE CORNER FILLETS .015 MAX; SURFACE FINISH $\sqrt{125}$ GEOMETRIC SYMBOLS PER ASME Y14.5		
SPECIFICATION CLASSIFICATION		
CLASSIFICATION	DIMENSION CALLOUT	NOTE NO. CALLOUT
CRITICAL	<XX.XX>	<#>
MAJOR	[XX.XX]	[#]
MINOR	XX.XX	#
REFERENCE	(XX.XX)	(#)

USER IS RESPONSIBLE FOR VERIFICATION OF CURRENT REVISION BEFORE USING THIS DOCUMENT. DOCUMENT CONSIDERED "REFERENCE ONLY" IF NOT THE CURRENT REVISION.

THIS DRAWING CONTAINS INFORMATION THAT IS CONFIDENTIAL AND PROPRIETARY TO HARTZELL ENGINE TECHNOLOGIES. THIS DRAWING IS FURNISHED ON THE UNDERSTANDING THAT THE DRAWING AND THE INFORMATION IT CONTAINS WILL NOT BE COPIED OR DISCLOSED TO OTHERS EXCEPT WITH THE WRITTEN CONSENT OF HARTZELL ENGINE TECHNOLOGIES. WILL NOT BE USED TO THE DETRIMENT OF HARTZELL ENGINE TECHNOLOGIES, AND WILL BE RETURNED ON REQUEST BY HARTZELL ENGINE TECHNOLOGIES.

DRAFTER	OKQ	02/28/20
ENGINEER	B. HENARD	
APPRVD.	129747	
FINISH	N/A	
WEIGHT	N/A	
MATERIAL	N/A	
SCALE	SIZE	SHEET
1:2	B	1 OF 1
CODE ID	65PY1	

 <p>2900 Selma Highway Montgomery, AL 36108</p>	INSTALLATION INSTRUCTIONS, ST5	
	ST60001	E