

4

3

2

1

INSTALLATION INSTRUCTIONS:

1. DISCONNECT STARTER POWER CABLE AND DISCARD NUT. UNBOLT STARTER FROM ENGINE AND RETAIN MOUNTING NUT(S)/BOLT(S).
2. INSPECT POWER CABLE, TERMINAL, AND INSULATOR BOOT. CLEAN OR REPLACE AS NEEDED.
3. TRIAL MOUNT NEW STARTER, FINGER TIGHTENING NUTS/BOLT(S) WITHOUT LOCK WASHERS TO OBSERVE FIT AND CLEARANCE. ADDRESS ANY BAFFLING MODIFICATIONS REQUIRED SO THAT NO AIRFRAME COMPONENTS INTERFERE, TOUCH, OR RUB THE STARTER WHEN INSTALLED. IF NEW STARTER MODEL IS NOT SUITABLE FOR APPLICATION, CONTACT FACTORY AT 800-476-7896 TO DISCUSS MODEL APPLICABILITY. B
4. REMOVE SUPPLIED M8 NUT, INTERNAL TOOTH LOCK WASHER, AND BLACK INSTRUCTION TAG FROM POWER TERMINAL AND RETAIN. READ TAG. IF AIRCRAFT OWNER WISHES, SEPARATE PLACARD AT THE TAG PERFORATION AND APPLY PLACARD TO INSTRUMENT PANEL.
5. INSTALL NEW STARTER USING 4 INCLUDED INTERNAL TOOTH LOCK WASHERS UNDER MOUNTING NUT(S)/BOLT(S) AND TORQUE TO 100 IN-LBS.
6. ATTACH AIRCRAFT STARTER POWER CABLE TO POWER TERMINAL. INSTALL M8 INTERNAL TOOTH LOCK WASHER AND NUT. ONLY USE SUPPLIED METRIC M8 NUT. USING 13MM WRENCH OR SOCKET, TORQUE M8 NUT TO 60 IN-LBS. COVER POWER TERMINAL WITH NEW OR EXISTING MS25171 INSULATOR BOOT.
7. INSTRUCTIONS FOR CONTINUED AIRWORTHINESS: AT 2700 HOURS OF ENGINE OPERATION, COINCIDENT WITH ENGINE OVERHAUL, OR IF SERVICING IS REQUIRED, STARTER SHOULD BE REPLACED WITH FACTORY NEW UNIT OR RETURNED TO FACTORY FOR REBUILD. NO OTHER PERIODIC INSPECTION OR MAINTENANCE OF ANY SKYTEC STARTER OR ITS COMPONENTS IS REQUIRED. A SUITABLE LIGHT DUTY RUST PREVENTATIVE LUBRICANT MAY BE APPLIED OCCASIONALLY TO EXPOSED STEEL DRIVE COMPONENTS TO GUARD AGAINST SURFACE OXIDATION. B

REVISIONS				
ECO	REV.	DESCRIPTION	BY	DATE
123517	B	1) REDRAWN IN SOLIDWORKS; 2) FORMAT: HET WAS SKYTEC; 3) REMOVED PMA DATA TABLE AND LABEL GRAPHIC; 4) REMOVED INSTALLATION AID	EAB	10/20/16

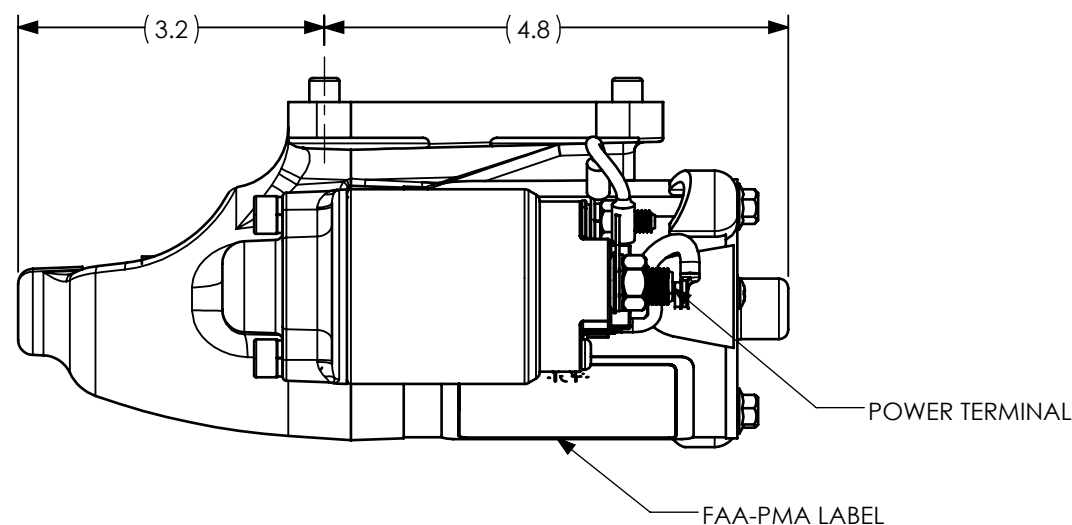
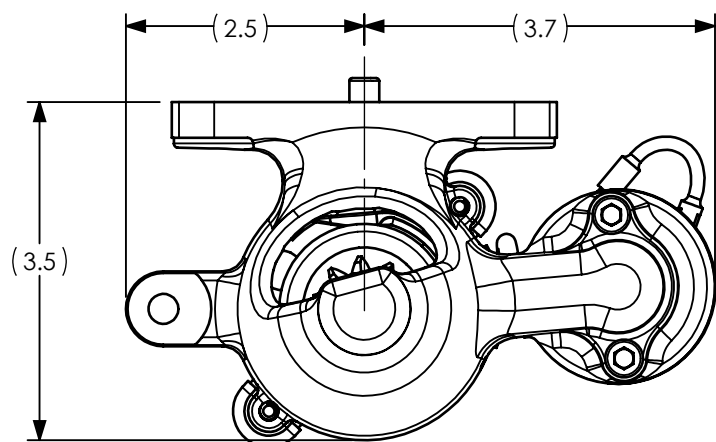

D

D

C

C

B

B

A

A

B

USER IS RESPONSIBLE FOR VERIFICATION OF CURRENT REVISION BEFORE USING THIS DOCUMENT. DOCUMENT CONSIDERED "REFERENCE ONLY" IF NOT THE CURRENT REVISION.

B

SPECIFICATION CLASSIFICATION		
CLASSIFICATION	DIMENSION CONVENTION	NOTE NO. CONVENTION
CRITICAL	<XX.XX>	<#>
MAJOR	[XX.XX]	[#]
MINOR	XX.XX	#
REFERENCE	(XX.XX)	(#)

UNLESS OTHERWISE SPECIFIED

DIMENSIONS ARE IN INCHES AND APPLY AFTER HEAT TREAT AND PLATING

.X = ±.015
.XX = ±.010 ANGLES ±1°
.XXX = ±.005

BREAK ALL EDGES AND MACHINE ALL INSIDE CORNER FILLETS .015 MAX.

SURFACE FINISH $\sqrt{125}$

THIS DRAWING CONTAINS INFORMATION THAT IS CONFIDENTIAL AND PROPRIETARY TO HARTZELL ENGINE TECHNOLOGIES. THIS DRAWING IS FURNISHED ON THE UNDERSTANDING THAT THE DRAWING AND THE INFORMATION IT CONTAINS WILL NOT BE COPIED OR DISCLOSED TO OTHERS EXCEPT WITH THE WRITTEN CONSENT OF HARTZELL ENGINE TECHNOLOGIES. WILL NOT BE USED TO THE DETRIMENT OF HARTZELL ENGINE TECHNOLOGIES, AND WILL BE RETURNED UPON REQUEST BY HARTZELL ENGINE TECHNOLOGIES.

GEOMETRIC SYMBOLS PER ANSI Y14.5	
	FLATNESS
	STRAIGHTNESS
	ROUNDNESS
	CYLINDRICITY
	PROFILE
	PERPENDICULARITY
	POSITION
	CONCENTRICITY
	SYMMETRY
	ANGULARITY
	PARALLELISM
	CIRCULAR RUNOUT
	TOTAL RUNOUT
SCALE	1:2

DRAWN	EAB	10/20/16
ENGINEER	K. NORD	
APPRVD.	123517	
FINISH	N/A	
WEIGHT	N/A	
MATERIAL	N/A	
SIZE	SH 1 OF 1	CODE ID 65PY1
B		

B

2900 Selma Highway
Montgomery, AL 36108

XL T INSTALLATION INSTRUCTIONS

DRAWING NO.	REV.
ST21001	C

4

3

2

1